

START FROM HERE

- Make sure power is completely off at the fuse box.
- Have your fixture installed by a qualified licensed electrician
- Prepare everything in a clear area.
- Wear gloves at all times during this installation.
- Read instructions carefully before you start assembly.
- Keep this instruction sheet for future reference.

Technical Support: 1-877-452-6858

Please Note:

- All Kuzco LED fixtures come with pre-wired LED module(s).
- Unless instructed to do so, please do not touch any part of the LED module(s) as any unnecessary contact with the module could cause permanent damage.
- For dimming, an ELV (Electronic Low Voltage) type of dimmer is required.

1. Remove the fixture from its original packaging. Remove the mounting plate (**1b**) from within the canopy (**1d**) by removing the 2 decorative nuts (**2f**). Attach the mounting plate (**1b**) to the electrical junction box (**1a**), using the two screws (**1c**) provided in the hardware package.

2. You are now ready to mount the canopy (**1e**) to the mounting plate (**1b**). Attach all wiring (**1d**) with the provided marrets (white to white "N", black to black "L", ground to ground "G"). Align the studs (**1b**) in the mounting plate to the holes on the canopy. Once aligned, screw on the two nuts (**2f**) provided to the studs (**1b**) this will secure the canopy to the back plate (**1b**).

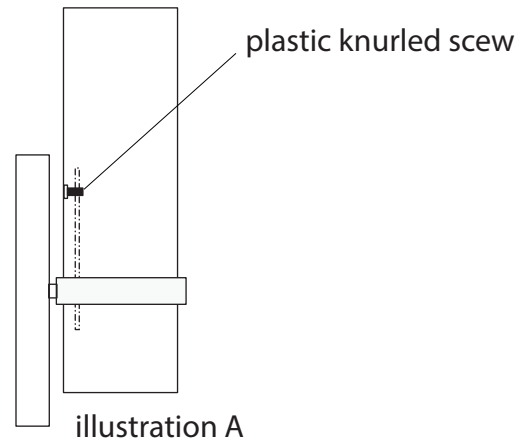

3. You can now install the T-10 light bulb of the correct wattage.

4. Before installing the glass cover onto the fixture, turn the plastic adjustment screw to help secure the desired position of the glass cover (see illustration A)

During the adjustment process you may need to install and remove the glass cover a number of times before its desired tension is achieved. It may also be required to physically correct the glass tilt with your hand.

5. You have now completed the installation of your fixture, enjoy.

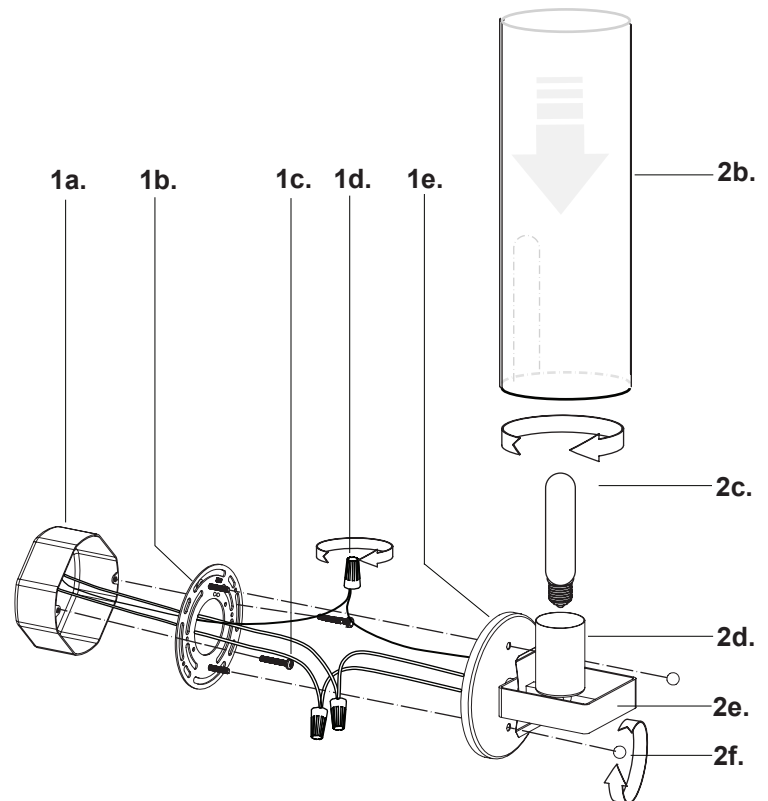

KUZCO

LIGHTING

19054 28th Avenue Surrey, BC Canada V3S 6M3
 T: 604 538 7162 TF: 1-855 85 KUZCO F: 604 538 7196
 W: kuzcolighting.com
 20160601